

In the
United States Court of Appeals
For the Seventh Circuit

No. 21-1649

LIFE SPINE, INC.,

Plaintiff-Appellee,

v.

AEGIS SPINE, INC.,

Defendant-Appellant.

Appeal from the United States District Court for the
Northern District of Illinois, Eastern Division.
No. 19-cv-7092 — **Young B. Kim**, *Magistrate Judge*.

ARGUED JULY 21, 2021 — DECIDED AUGUST 9, 2021

Before SCUDDER, ST. EVE, and KIRSCH, *Circuit Judges*.

ST. EVE, *Circuit Judge*. This trade secret case arises from a short-lived business relationship between two companies that sell spinal implant devices. Life Spine, Inc. makes and sells a spinal implant device called the ProLift Expandable Spacer System. Aegis Spine, Inc. contracted with Life Spine to distribute the ProLift to hospitals and surgeons. In the distribution agreement, Aegis promised to protect Life Spine's confidential information, act as a fiduciary for Life Spine's property,

and refrain from reverse engineering the ProLift. Despite these promises, Aegis funneled information about the ProLift to its parent company, L&K Biomed, Inc., to help L&K develop a competing spinal implant device. Shortly after L&K's competing product hit the market, Life Spine sued Aegis for trade secret misappropriation and breach of the distribution agreement. Following a nine-day evidentiary hearing, the district court granted Life Spine's motion for a preliminary injunction barring Aegis and its business partners from marketing the competing product.

Aegis now appeals. It submits that the district court's injunction rests on a flawed legal conclusion—namely, that a company can have trade secret protection in a device that it publicly discloses through patents, displays, and sales. We see the issue differently, however. As a legal matter, we do not dispute—nor does Life Spine—that information in the public domain cannot be a trade secret. But the issue here is factual: Did Life Spine publicly disclose the specific information that it seeks to protect by patenting, displaying, and selling the ProLift? The district court found that the answer was no, and Aegis must show that its finding was clear error. It has not done so. Finding no basis to upset the district court's meticulous analysis, we affirm.

I. Background

A. Factual Background

Plaintiff Life Spine is an Illinois company that makes and sells surgically implanted medical devices that treat spine disorders. Its best-selling device is the ProLift—an expandable spinal implant that treats degenerative disc disease. The ProLift consists of an implant, or “cage,” and an installer. The

cage has five main components, shown in the drawing below: an upper endplate, a lower endplate, a nose ramp, a base ramp, and an expansion screw. Dovetail-shaped grooves connect the different components. The installer is used to insert the cage into a patient's spine and expand it to restore spinal disc height.

ProLift cage (exploded)

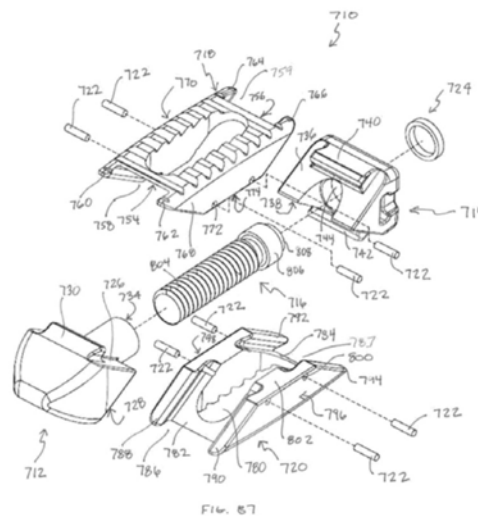

Expandable cages are intricate devices with many small component parts. Precise engineering is necessary to ensure that they can withstand decades of intense spinal pressure. Life Spine spent more than three years designing and developing the ProLift. To do so, it studied publicly available information about other expandable cages, including patents, and went through an exhaustive trial-and-error process. During the trial-and-error process, Life Spine repeatedly redesigned the device, sometimes by adjusting the size of its components by fractions of a millimeter. In March 2016, the FDA approved Life Spine's application to market the ProLift. In October 2017, Life Spine obtained a patent for the ProLift. Life Spine's

patent includes various drawings and figures (including the drawing above), along with descriptions of the components and their interaction.

Life Spine considers “the precise dimensions and measurements of the ProLift components and subcomponents and their interconnectivity” to be confidential trade secrets. A key fact in dispute is whether third parties can access those precise specifications without first signing confidentiality agreements. The district court found that the answer was no: Third parties can only learn such information if they have unfettered access to the device and specialized measuring equipment, and Life Spine does not allow third parties such access unless they first sign confidentiality agreements. The precise specifications of the ProLift are not available from marketing materials, which include only “rounded approximations” of the components. Nor are they available from patent materials, which disclose the components and their interaction but not their precise measurements or dimensions. Life Spine displays the ProLift at industry conventions, but it supervises anyone who handles the device. And while Life Spine sells the ProLift to hospitals and surgeons, it is not available for the public to purchase. Rather, Life Spine (through its distributors) sells the device to hospitals and surgeons, who purchase the device for use in scheduled surgeries. Moreover, Life Spine requires its distributors to oversee each ProLift device that they sell up until surgery.

Defendant Aegis is a Colorado company that sells medical devices to treat spinal conditions. Aegis does not make medical devices, but its parent company, L&K, does. Based in South Korea, L&K is the majority owner of Aegis and a direct competitor of Life Spine. Aegis and L&K have a close

relationship; Aegis supplies information to L&K upon request, and several of the companies' top managers have worked at both companies. Around April 2016, L&K and Aegis decided that, to remain competitive in the United States market, L&K should design and develop an expandable cage product.

In October 2017—while Aegis and L&K were still planning the launch of a new expandable cage product—Aegis contacted Life Spine about serving as a distributor of the ProLift. In connection with this proposal, Aegis asked Life Spine for a ProLift device, explaining that certain customers wanted to see it for demonstration purposes. Life Spine agreed, but first required Aegis to promise in writing that it would protect Life Spine's confidential information, use the confidential information only in furtherance of the parties' business relationship, and refrain from sharing the ProLift with anyone who intended to use it for purposes of reverse engineering, copying, or otherwise competing with Life Spine. After making these promises, Aegis showed the ProLift device to a surgeon and asked the surgeon to help it and L&K develop a competing expandable cage. The surgeon agreed.

In January 2018, Life Spine and Aegis signed a formal distribution agreement. The agreement (which superseded earlier agreements) allowed Aegis to solicit sales of the ProLift from a list of surgeons, including two surgeons who had agreed to help L&K develop a competing expandable cage. In return, Aegis promised to act as a fiduciary for Life Spine's property. Aegis also promised not to copy, reverse engineer, or create derivative products based on the ProLift. The agreement contained confidentiality provisions barring Aegis from sharing Life Spine's confidential information or using it for

any non-contractual purpose. It further required Aegis to train its employees on complying with these provisions and provided that the obligations would “survive the expiration” of the agreement.

In March 2018, Aegis held a kickoff meeting for L&K’s forthcoming expandable cage product, the AccelFix-XT. Aegis brought a ProLift set to the meeting, and its surgeon consultants examined it. The surgeon consultants continued to help Aegis and L&K throughout the design process; they purchased and used the ProLift in surgeries and gave feedback to Aegis and L&K on the device’s performance. Aegis and L&K incorporated their feedback into the design process.

In May 2018, Aegis sent L&K a ProLift cage. A month later, Aegis sent L&K a full ProLift set (cage and installer). L&K had asked to see the devices to help develop the AccelFix-XT. Aegis sent the devices to L&K without Life Spine’s knowledge or consent. After receiving the installer, L&K told Aegis that it was copying the basic design of the ProLift installer. Materials from a meeting a few months later show that L&K designed the AccelFix-XT installer to be compatible with the ProLift cage.

The district court described the evidence surrounding these device shipments as “murky.” L&K’s head of Research and Development claimed that he never saw the cage that Aegis sent over in May 2018. As for the full ProLift set that Aegis sent over in June, he testified that he decided not to open the package because he did not want L&K to have to pay for it. He maintained that L&K returned the unopened box to Aegis, but he could not recall any details about returning it, nor was there any other evidence to verify the return. Aegis eventually told Life Spine that Aegis had received an empty box from

Life Spine, without a cage in it. But Life Spine was skeptical; it had never had such a problem in the past, and a photo of the “empty box” showed that someone had affixed a second antitampering sticker over the original one. Life Spine suspected that someone had opened the box, removed the cage, and then tried to cover it up. The district court ultimately agreed, concluding that L&K’s explanation to the contrary was not credible.

The distribution agreement between Life Spine and Aegis expired on August 31, 2018, but the parties chose to continue their arrangement for the time being. In September 2018, Aegis and Life Spine orally agreed that the parties would continue to operate under the terms of the distribution agreement while they negotiated a new contract. Aegis continued to submit purchase orders, and Life Spine continued to fill them.

Around the same time, Aegis asked Life Spine for a custom installer to show its customers. In September 2018, Life Spine sent Aegis an email with a picture and details about the custom installer. Aegis forwarded the email to L&K, despite knowing that Life Spine considered it confidential.

Life Spine never shared ProLift testing data with Aegis, but Aegis somehow obtained it. The materials from an October 2018 meeting between L&K and Aegis include a reference to the results of a “static shear compression test” for the ProLift. A static shear compression test measures how much load a cage can withstand on a one-time basis before breaking or deforming. Life Spine considers the results of its static shear compression testing to be confidential trade secrets. It submitted the results to the FDA when applying for approval to market the ProLift, but it did not otherwise disclose them. Because the FDA approved the ProLift (and, by extension, its testing

results), a competitor with access to ProLift testing results would have a leg up in the trial-and-error process. Aegis could not explain how it obtained the testing results. The district court found that “the most likely explanation is that L&K used its access to the ProLift cage to conduct its own testing.”

In December 2018, development of the AccelFix-XT was going poorly, so L&K decided to start from scratch. Three months later, in March 2019, L&K applied for FDA approval to market the AccelFix-XT. By FDA regulation, medical device developers must keep “design history files” that reflect each step in the design of a medical device. *See* 21 C.F.R. § 820.30(j). But there is almost no documentation in the AccelFix-XT design history file from January 2019 through April 2019. During that short period, as it happens, L&K redesigned the AccelFix-XT to change a square component to a dovetail feature, such that its key measurements were essentially identical to the ProLift’s dovetail feature. The design history file does not reflect the process behind that redesign. The FDA approved the AccelFix-XT in September 2019.

Meanwhile, the parties’ distribution relationship had ended. In December 2018, Aegis directly purchased 45 ProLift cages from Life Spine. Attempts to formally renew the relationship, however, were unsuccessful. In the spring and summer of 2019, Aegis and Life Spine attempted to negotiate a new agreement. In July 2019, however, Aegis backed out of negotiations. In September 2019, Life Spine first learned that Aegis and L&K were launching the AccelFix-XT in direct competition with the ProLift.

B. Procedural Background

Shortly after learning of the AccelFix-XT, Life Spine sued Aegis for breaching the distribution agreement and misappropriating its trade secrets in violation of the Defend Trade Secrets Act, 18 U.S.C. § 1836 *et seq.*, and the Illinois Trade Secrets Act, 765 ILCS 1065/1 *et seq.* The parties consented to Magistrate Judge Kim’s jurisdiction. *See* 28 U.S.C. § 636(c).

In August 2020, Life Spine moved for a preliminary injunction. The district court held a nine-day hearing on the motion. Representatives from both sides testified, as did John Ashley, a seasoned medical device developer whom Life Spine called as an expert witness. Ashley testified that the ProLift cage and the AccelFix-XT cage are “essentially the same.” Both devices have the same five essential components—two endplates, a nose ramp, a base ramp, and an expansion screw—which function together in substantially the same way. In both devices, the endplates and ramps connect via dovetail-shaped grooves and a screw that controls the cage’s expansion. The dovetails’ specifications vary by mere fractions of a millimeter. Remarkably, the ProLift installer is compatible with the AccelFix-XT cage, which Ashley found “shocking” and unprecedented in his experience. Even Aegis’s CEO conceded that it would be “impossible” to produce a cage compatible with another company’s installer without knowing the specifications of the other company’s cage.

Ashley was surprised at how fast L&K developed the AccelFix-XT after starting from scratch in December 2018. He testified that 18 months is a reasonable timeframe for developing an expandable cage, and that the three-month period for L&K was much shorter than he would have expected. He also commented on the lack of documentation in the design

history file. After reviewing 20 different expandable cage devices, Ashley concluded that the ProLift and AccelFix-XT were the only two devices that were “essentially the same.” This led him to conclude that the AccelFix-XT was a “derivative product” based on the ProLift cage. In his opinion, L&K used either the ProLift cage itself or detailed information about the ProLift to develop the AccelFix-XT.

After hearing the evidence, the district court granted Life Spine’s motion for a preliminary injunction. It set forth its reasoning in a 65-page order that comprehensively analyzed the facts and legal arguments. On the merits, the court found that Life Spine had a strong likelihood of success on its trade secret misappropriation claim and its breach of contract claims. Specifically, Life Spine made a strong showing that Aegis had misappropriated three distinct trade secrets: “(1) the combination, dimensions, and interconnectivity of the ProLift’s components and subcomponents; (2) static shear compression testing data; and (3) information about how Life Spine prices the ProLift.” As for the breach of contract claim, Life Spine made a strong showing that Aegis had breached the confidentiality, fiduciary duty, and anticopying provisions of the distribution agreement. The court also found, as a preliminary matter, that each of these provisions survived the agreement’s expiration. Moving to the other injunction factors, the court found that Life Spine had suffered irreparable harm in the form of lost customers and market share, damaged goodwill and reputation, and price erosion. It found, too, that the harm to Life Spine of denying an injunction outweighed the harm to Aegis of granting one. Based on these findings, the district court enjoined Aegis and its business partners from making, marketing, distributing, selling, or obtaining intellectual property rights in the AccelFix-XT.

Aegis filed an interlocutory appeal of the order granting the preliminary injunction. *See* 28 U.S.C. § 1292(a)(1).

II. Discussion

To obtain a preliminary injunction, a plaintiff must show that it is likely to succeed on the merits, and that traditional legal remedies would be inadequate, such that it would suffer irreparable harm without the injunction. *Speech First, Inc. v. Killeen*, 968 F.3d 628, 637 (7th Cir. 2020). If the plaintiff makes this showing, the court weighs the harm of denying an injunction to the plaintiff against the harm to the defendant of granting one. *Id.* This balancing test is done on a sliding scale: “If the plaintiff is likely to win on the merits, the balance of harms need not weigh as heavily in his favor.” *Id.* In balancing the harms, the court also considers the public interest. *Id.*

We review a district court’s decision to grant or deny a preliminary injunction for abuse of discretion. *Id.* at 638. In doing so, we review the court’s legal conclusions de novo and its factual findings for clear error. *Id.* Absent legal or factual errors, we afford “great deference” to the court’s decision. *Id.* (internal quotation and citation omitted).

A. Likelihood of Success on the Merits

Aegis’s appeal focuses primarily on Life Spine’s likelihood of success on the merits. For present purposes, Aegis does not dispute that L&K used the information that Aegis shared with it to reverse engineer the ProLift. Instead, Aegis maintains that none of the shared information was confidential. In Aegis’s view, the district court legally erred in finding that Life Spine could have trade secret protection in information that it publicly disclosed through patents, displays, and sales. Aegis

maintains that this error permeated the court's assessment of the merits.

We recently clarified that “a plaintiff must demonstrate that its claim has some likelihood of success on the merits, not merely a better than negligible chance.” *Mays v. Dart*, 974 F.3d 810, 822 (7th Cir. 2020) (internal quotations and citations omitted). In other words, “a mere possibility of success is not enough.” *Ill. Republican Party v. Pritzker*, 973 F.3d 760, 762 (7th Cir. 2020). The precise showing necessary “depends on the facts of the case at hand because of our sliding scale approach.” *Mays*, 974 F.3d at 822.

1. Trade Secret Misappropriation

Life Spine brings parallel trade secret misappropriation claims under federal and state law. Under federal law, information qualifies as a “trade secret” if (1) “the owner thereof has taken reasonable measures to keep such information secret” and (2) “the information derives independent economic value, actual or potential, from not being generally known to, and not being readily ascertainable through proper means by, another person who can obtain economic value from the disclosure or use of the information.” 18 U.S.C. § 1839(3). Illinois's definition is materially identical. 765 ILCS 1065/2(d). Under both statutes, whether information qualifies as a trade secret is a question of fact that “requires an ad hoc evaluation of all the surrounding circumstances.” *Learning Curve Toys, Inc. v. PlayWood Toys, Inc.*, 342 F.3d 714, 723 (7th Cir. 2003).

Although the existence of a trade secret is a question of fact, there are some general rules that guide the inquiry. Relevant here, “[i]nformation that is public knowledge or that is generally known in an industry cannot be a trade secret.”

Ruckelshaus v. Monsanto Co., 467 U.S. 986, 1002 (1984); accord *Pope v. Alberto-Culver Co.*, 694 N.E.2d 615, 617 (Ill. App. Ct. 1998). Thus, a company may not publicly disclose information in a patent and then claim that the information is a trade secret. “Publication in a patent destroys the trade secret.” *BondPro Corp. v. Siemens Power Generation, Inc.*, 463 F.3d 702, 706 (7th Cir. 2006). Similarly, a company may not publicly sell or display a product and then claim trade secret protection in information that is “readily ascertainable” upon examination of the product. Restatement (Third) of Unfair Competition § 39 cmt. f (1995); accord *Accent Packaging, Inc. v. Leggett & Platt, Inc.*, 707 F.3d 1318, 1329 (Fed. Cir. 2013); *Pope*, 694 N.E.2d at 618; 1 *Milgrim on Trade Secrets* § 1.05 (2021).

Importantly, though, a limited disclosure does not destroy all trade secret protection in a product. *Rockwell Graphic Sys., Inc. v. DEV Indus., Inc.*, 925 F.2d 174, 176–77 (7th Cir. 1991). Trade secret law focuses on the “concrete secrets” that the plaintiff seeks to protect, rather than “broad areas of technology.” *Composite Marine Propellers, Inc. v. Van Der Woude*, 962 F.2d 1263, 1266 (7th Cir. 1992). Thus, a company can maintain trade secret protection in the undisclosed aspects of a product, even if it has publicly disclosed other aspects of the same product. See, e.g., *Henry Hope X-Ray Prods., Inc. v. Marron Carrel, Inc.*, 674 F.2d 1336, 1342 (9th Cir. 1982) (patent drawings did not destroy trade secret protection because they provided “only a general depiction of a gearing system” and did not disclose the precise information that the plaintiff sought to protect); see also *Wellogix, Inc. v. Accenture, L.L.P.*, 716 F.3d 867, 875 (5th Cir. 2013) (“[A] patent destroys the secrecy necessary to maintain a trade secret only when the patent and the trade secret both cover the same subject matter.”) (internal quotation and citation omitted). A trade secret can even exist “in a

combination of characteristics and components, each of which, by itself, is in the public domain,” so long as their “unique combination” has competitive value. *3M v. Pribyl*, 259 F.3d 587, 595–96 (7th Cir. 2001); accord Restatement (Third) of Unfair Competition § 39 cmt. f.

By the same token, a company does not forfeit trade secret protection by publicly displaying or selling a product unless the trade secret is “readily ascertainable” upon examination of the product. Restatement (Third) of Unfair Competition § 39 cmt. f. (“[I]f acquisition of the information through an examination of a competitor’s product would be difficult, costly, or time-consuming, the trade secret owner retains protection against an improper acquisition, disclosure, or use.”); accord *Televation Telecomm. Sys., Inc. v. Saindon*, 522 N.E.2d 1359, 1365 (Ill. App. Ct. 1988); 1 *Milgrim on Trade Secrets* § 1.05; see also *Hicklin Eng’g, L.C. v. Bartell*, 439 F.3d 346, 350 (7th Cir. 2006); *Thermodyne Food Serv. Prod., Inc. v. McDonald’s Corp.*, 940 F. Supp. 1300, 1307 (N.D. Ill. 1996).

These teachings reveal a critical flaw in Aegis’s argument. Aegis contends that the district court legally erred in concluding that information about the ProLift could remain a protected trade secret after Life Spine patented, displayed, and sold the device to hospitals and surgeons. Aegis appears to view trade secret protection as an all-or-nothing proposition for a given product—either it exists, or it does not. But the inquiry is more nuanced than that. We focus on the precise information that the plaintiff seeks to protect and ask if it qualifies as a trade secret under the relevant statutory definition. That is precisely what the district court did here; it did not legally err. To be sure, if it turns out that the precise information is known to the public, or is general knowledge in the

industry, then there is no trade secret. *Ruckelshaus*, 467 U.S. at 1002. But whether the information is public is a question of fact. *Learning Curve*, 342 F.3d at 723; *Atl. Rsch. Mktg. Sys., Inc. v. Troy*, 659 F.3d 1345, 1357 (Fed. Cir. 2011) (whether patent disclosed alleged trade secrets was a question for the jury).

Properly framed, then, the issue here is factual: Did Life Spine publicly disclose its alleged trade secrets by patenting, displaying, and selling the ProLift? The district court found that the answer was no, and Aegis does not come close to showing that its detailed finding was clear error.

To begin, ample evidence supports the district court's finding that Life Spine's patent did not disclose the precise specifications of the ProLift. Life Spine's engineering manager testified that the precise specifications are "not easily derived" from patent materials. Expanding on that point, Life Spine's director of engineering explained that the measurements of the ProLift's dovetail component are extremely precise—down to fractions of a millimeter. And these granular measurements are not available from patent materials, which include only "pictures of the part" and do not "go into detail," provide dimensions, or "tell anyone how the features connect, how it's assembled." A third party can learn the precise measurements only with access to the device itself and sophisticated measurement technology.

To counter this evidence, Aegis points to Life Spine expert Ashley's concession that some measurements of the ProLift are standard in the industry and that an engineer reading Life Spine's patent would have a good "starting point" for ascertaining some of the other measurements. But Ashley's testimony does not support a finding that every dimension and measurement of the ProLift is in the public domain. Rather, it

supports a finding that the ProLift patent would be helpful to a company developing a competing product—a fact that is unremarkable and undisputed in this litigation. Nowhere did Ashley testify that Life Spine’s patent materials disclose the exact dimensions and measurements of every ProLift component. And it is these dimensions and measurements, rather than the product itself, which Life Spine seeks to protect as a trade secret.

Nor can Aegis show that the district court clearly erred in finding that Life Spine’s displays and sales did not disclose the precise specifications of the ProLift. The evidence showed—and Aegis does not dispute—that those who attend ProLift displays do not have unfettered access to the device. Rather, Life Spine supervises them as they handle the device, much like a jeweler supervises someone trying on a watch.

As for sales, the only purchasers of the ProLift are hospitals and surgeons, who purchase the device for use in scheduled surgeries. The evidence showed that Life Spine takes many precautions to safeguard the device prior to surgery. A Life Spine representative testified that Life Spine or its distributors ship the ProLift in sealed boxes affixed with antitampering stickers. For sterilization purposes, the boxes remain sealed until surgery. Moreover, Life Spine requires its distributors to oversee the devices until surgery. Distributors inspect the devices “prior to surgery and through surgery.” They keep documentation about the surgery and confirm with the hospital that the surgery went as planned. They must even be present in the operating room “to assist and answer any questions that the surgeon or his surgical staff has regarding the product that’s being used.” While carrying out these tasks, the distributors act as fiduciaries for Life Spine’s property.

Relying on this evidence, the district court found that Life Spine did not publicly disclose the precise specifications of the ProLift by selling it for use in surgeries. Aegis strains to explain why that finding was clear error. Distributors are bound by confidentiality agreements, so Aegis is left to suggest that surgeons or patients, who are not similarly bound, might reverse engineer the device. This speculative argument is hard to accept. As just mentioned, distributors acting as fiduciaries sell the device for use in specific surgeries and oversee the device throughout the process. Even apart from that, it seems doubtful that the hospitals or surgeons purchasing the device for use in planned surgeries would secretly unpackage the device, measure all its components with specialized measurement technology, reassemble the device, and then use the device in the surgery. It seems even more unlikely that a device would be removed from a patient's body and then reverse engineered. Aegis has not identified any evidence that supports these unfounded scenarios.

The district court was not obligated to credit Aegis's speculative and factually unsupported hypotheses. After all, the owner of a trade secret need only take "reasonable measures" to preserve secrecy. 18 U.S.C. § 1839(3). Life Spine takes many steps to protect the secrecy of the precise specifications of the ProLift. It does not take every conceivable measure—but it is not required to do so. *See Rockwell Graphic Sys.*, 925 F.2d at 177–80. The district court's factual finding that the precise specifications of the ProLift are trade secrets has substantial evidentiary support and does not approach clear error.

Unable to show clear error, Aegis retreats to legal arguments. It leans heavily on the Eleventh Circuit's decision in *Roboserve, Ltd. v. Tom's Foods, Inc.*, 940 F.2d 1441 (11th Cir.

1991). But *Roboserve* is distinguishable. There, the court held that Roboserve lost trade secret protection in a vending machine by selling nearly 1,300 machines to a company that resold them to distributors who had “no direct connection to Roboserve.” *Id.* at 1455. In other words, Roboserve’s vending machine was not secret because countless distributors had unlimited access to it. Here, by contrast, the district court found that Life Spine’s trade secrets are not in the public domain; rather, they are accessible only to third parties who sign confidentiality agreements.

Aegis only briefly challenges the district court’s finding that Life Spine’s testing data and pricing information qualify as trade secrets. Aegis claims the testing data was not a trade secret because, at most, Aegis obtained the information by reverse engineering a publicly disclosed product. As explained, though, the district court found that the relevant details of the ProLift were not public, so this argument fails for reasons described above.

As to pricing, Aegis suggests that it obtained no economic value from that information. But the district court found that Aegis used its knowledge of the ProLift distributor price to undercut Life Spine in competing for customers. And, in any event, trade secret protection extends to information that has “actual or potential value.” 18 U.S.C. § 1839(3) (emphasis added). Aegis argues as well that the district court applied the wrong standard when it concluded that Life Spine had only “some likelihood” of success in showing that its standard distributor price is a trade secret that Aegis misappropriated. But the court did not err: “Some likelihood” is the correct standard. *Mays*, 974 F.3d at 822; see also *Pritzker*, 973 F.3d at 763

(noting that the overlapping standard for granting a motion to stay requires a “strong showing” of success).

2. Breach of Contract

The district court found that Life Spine was likely to succeed in proving that Aegis breached three sections of the distribution agreement: the confidentiality provisions, the fiduciary duty provisions, and the anticopying provisions. Aegis challenges some aspects of these findings, along with the court’s preliminary determination that the relevant provisions survived the expiration of the distribution agreement.

Confidentiality. In the distribution agreement, Aegis promised “not to disclose” Life Spine’s confidential information and to use it “only for the purpose set forth in this Agreement.” It also required Aegis to train its employees on their confidentiality obligations. The district court found that Life Spine had a “high likelihood of success” on its claim that Aegis breached the confidentiality provisions by sharing Life Spine’s confidential information—specifically, the ProLift devices, pricing data, and the email about the custom installer—with L&K, and by failing to train its employees on their confidentiality obligations.

Aegis has little to say on this score. Relying on its trade secret argument, Aegis contends that the supposedly confidential information was already public, thus falling outside the agreement’s protections. But this argument fails for reasons already explained: Aegis has not shown that the district court clearly erred in finding that Life Spine did not publicly disclose its alleged trade secrets.

As for its failure to train its employees on their confidentiality obligations, Aegis maintains that Life Spine never

demonstrated how that breach led to any harm. But as the district court noted, two Aegis employees who admittedly never read the distribution agreement worked with L&K to develop the AccelFix-XT. This evidence permitted a finding that Aegis's failure to train its employees contributed to Life Spine's harm: If the employees had known of their confidentiality obligations, it is reasonable to infer that they may not have participated in a scheme to disclose Life Spine's confidential information to a direct competitor.

Fiduciary duties. The distribution agreement required Aegis to "maintain custody and/or control of each item of Inventory in a fiduciary capacity, as a trustee of [Life Spine's] property rights therein." The district court found that Aegis violated its fiduciary duties by transferring custody of the ProLift devices to L&K, and by sharing the ProLift with its surgeon consultants.

Aegis maintains that, even if it breached its fiduciary duties, the injunction is overbroad. We disagree. The district court found that Aegis shipped ProLift devices to L&K to help it develop a competing product. It shared the devices with its consultants, too, so that they could provide feedback. The final product—the AccelFix-XT—could reasonably be viewed as a product of those breaches, given that both breaches furthered its development. An injunction prohibiting Aegis from profiting from the product of its breaches is proportionate. *Cf. Foodcomm Int'l v. Barry*, 328 F.3d 300, 305 (7th Cir. 2003).

Anticopying. The distribution agreement forbade Aegis from "copy[ing]," "reverse engineer[ing]," or "creat[ing] derivative works" based on the ProLift. The district court found, however, that Life Spine was likely to succeed in proving that Aegis did just those things in concert with L&K. Aegis's

defense is legal, rather than factual. It contends that federal patent law preempts the anticopying provision, such that its breach (if any) of that provision cannot sustain the injunction. This argument surfaces for the first time on appeal, so it is waived. See *Henry v. Hulett*, 969 F.3d 769, 786 (7th Cir. 2020) (en banc). It is also meritless. Courts rarely, if ever, hold that federal intellectual property law preempts a “simple two-party contract,” which binds only the parties to the contract and therefore does not frustrate federal policies. *ProCD, Inc. v. Zeidenberg*, 86 F.3d 1447, 1453–55 (7th Cir. 1996); accord *Bowers v. Baystate Techs., Inc.*, 320 F.3d 1317, 1323–26 (Fed. Cir. 2003); see also *Aronson v. Quick Point Pencil Co.*, 440 U.S. 257, 264 (1979). Aegis does not convince us that the agreement’s anticopying provisions interfere with federal patent policy.

Survival clause. As a more general matter, Aegis argues that the distribution agreement did not apply to its direct purchase of 45 ProLift devices in December 2018, months after the agreement expired on August 31, 2018. It disclaims any supposed breaches flowing from those direct sales. The district court rejected this argument because of the agreement’s survival clause, which provides: “Notwithstanding anything to the contrary in this Agreement,” the relevant provisions “will survive the expiration or termination of this Agreement.” Aegis maintains that the December 2018 purchases were not governed by the distribution agreement because they postdated its expiration and they were direct purchases rather than consignment-based sales (in contrast to the parties’ earlier arrangement).

We need not, and do not, resolve this issue because even without the December 2018 sales, there was plenty of evidence supporting the district court’s finding that Aegis

breached the relevant contract provisions. Aegis does not dispute, for example, that it was bound by the distribution agreement in May and June 2018, when it shipped ProLift devices to L&K. And the district court permissibly found that those shipments alone breached Aegis's contractual duties: they breached the fiduciary duty provisions because Aegis was required to maintain custody over the shipped devices; they breached the confidentiality provisions because the shipped devices contained Life Spine's confidential information; and they breached the anticopying provisions because, as the district court found, Aegis and L&K used the shipped devices to reverse engineer the ProLift. In fact, L&K told Aegis after receiving the ProLift installer that it was copying its basic design. So, even without the breaches, if any, stemming from the December 2018 sales, the district court's breach of contract analysis stands.

Even so, we make a few observations for further proceedings. The survival clause, though relevant, does not fully resolve this issue. That clause merely provides that the parties' duties will survive the expiration of the agreement. But that begs the question: What is the scope of those duties? Answering that question requires examining precisely what the parties' duties were under the distribution agreement. Survival clause aside, a separate question is whether the parties entered a binding oral contract to renew the distribution agreement in September 2018, such that its terms remained in effect in December 2018. The agreement provides that it "may be extended by mutual consent of both parties in writing." And indeed, the parties pursued that option twice, executing two written addenda that extended the agreement by four months. But even if the agreement implicitly banned oral extensions, Illinois law (which governs all claims under the

agreement) permits oral modification despite such bans. *See, e.g., U.S. Neurosurgical, Inc. v. City of Chicago*, 572 F.3d 325, 332 (7th Cir. 2009); *Czapla v. Commerz Futures, LLC*, 114 F. Supp. 2d 715, 718–19 (N.D. Ill. 2000); *A.W. Wendell & Sons, Inc. v. Qazi*, 626 N.E.2d 280, 287 (Ill. App. Ct. 1993). Neither the court below nor the parties fully address these issues, so we do not resolve them in this appeal.

B. Irreparable Harm

A finding of irreparable harm absent an injunction “is a threshold requirement for granting a preliminary injunction.” *Foodcomm*, 328 F.3d at 304. Harm is irreparable if legal remedies are inadequate to cure it. *Id.* Inadequate “does not mean wholly ineffectual; rather, the remedy must be seriously deficient as compared to the harm suffered.” *Id.*

Aegis contends that the district court wrongly relied on a presumption of irreparable harm. It adds that the harm stemming from Life Spine’s loss of customers and market share is quantifiable and thus remediable through damages.

To start, we agree that the district court erred in relying on a presumption of irreparable harm. The district court thought a presumption of irreparable harm attached upon a showing of likely success on a trade secret claim. And indeed, that used to be true in this circuit. *Atari, Inc. v. N. Am. Philips Consumer Elecs. Corp.*, 672 F.2d 607, 620 (7th Cir. 1982). But the Supreme Court rejected such a presumption in *eBay Inc. v. MercExchange, L.L.C.*, 547 U.S. 388, 393 (2006), as we explained in *Flava Works, Inc. v. Gunter*, 689 F.3d 754, 755 (7th Cir. 2012); *see also First W. Cap. Mgmt. Co. v. Malamed*, 874 F.3d 1136, 1143 (10th Cir. 2017).

All the same, the court's error was harmless. The court spent one page of its analysis on the presumption before moving on to explain why Life Spine had shown irreparable harm even without the presumption. For one thing, Life Spine presented evidence that it would lose customers and market share because Aegis was marketing the AccelFix-XT "in the same finite pool of hospitals and surgeons in which Life Spine markets the ProLift." Granted, harm stemming from lost customers or contracts may be quantifiable if the lost customers or contracts are identifiable. But here, the district court found that they were not fully identifiable. Rather, because hospitals do not publicize their contracts for spinal products, identifying and quantifying lost business "would be especially difficult" for Life Spine. And we have held that "it is precisely the difficulty of pinning down what business has been or will be lost that makes an injury 'irreparable.'" *Hess Newmark Owens Wolf, Inc. v. Owens*, 415 F.3d 630, 632 (7th Cir. 2005).

Beyond lost customers and market share, the district court found that Life Spine had "some likelihood" of proving irreparable harm stemming from the loss of goodwill and reputation. The court explained that Life Spine had worked to develop "niche contracts" with hospitals by marketing the ProLift as a unique product. The nearly identical AccelFix-XT would undercut that strategy, thereby damaging Life Spine's goodwill and reputation. And it is well established that the loss of goodwill and reputation, if proven, can constitute irreparable harm. *Stuller, Inc. v. Steak N Shake Enters., Inc.*, 695 F.3d 676, 680 (7th Cir. 2012); 11A Charles Alan Wright & Arthur R. Miller, *Federal Practice & Procedure* § 2948.1 (3d ed. 2002 & April 2021 Supp.) ("Injury to reputation or goodwill is not easily measurable in monetary terms, and so often is viewed as irreparable.").

The district court's finding of irreparable harm stemming from loss of customers and loss of goodwill and reputation is sufficient to sustain the injunction, so its error in applying a presumption of irreparable harm does not warrant reversal. We do not rely on the court's finding of irreparable harm stemming from "price erosion" because it is not clear to us why any such harm (e.g., being forced to reduce prices to remain competitive) would not be quantifiable.

C. Balancing Test and the Public Interest

We easily uphold the district court's careful balancing of the harms. The court acknowledged that Aegis's purported harms—pulling a product, losing revenue, laying off employees, and possibly going out of business—were "real and serious harms." It found, however, that the evidence did not fully support Aegis's claimed harms: Aegis had existed for a decade before it started selling the AccelFix-XT, and nothing in the injunction prevented it from selling other products, including other expandable cage products. As such, the potential harm to Aegis did not tip the balance. In the end, the court found that "the strength of Life Spine's showing of likely success" on the merits, "its strong showing of irreparable harm, and the public's interest in the enforcement of contracts and protection of trade secrets and confidential information" outweighed "the relatively weak evidence that Aegis would suffer catastrophic harm under the proposed injunction."

Beyond disagreeing with how the court balanced the harms, Aegis gives no good reason why the court abused its discretion in balancing the harms. The court acknowledged the competing interests at stake, properly calibrated the inquiry based on Life Spine's strong merits showing, and considered the public interest. We find no abuse of discretion.

III. Conclusion

For these reasons, we affirm the preliminary injunction. We commend Judge Kim for his thorough and precise analysis in this complex case.